



SHIP'S PARTICULARS



M/V "CONDOR BILBAO"

Port of registry	LIMASSOL
Flag	CYPRUS
Call Sign	5BAR5
IMO no.	9473250
Owners	Condor Bilbao Two Shipping Co. Ltd.
Operator	NSC Shipping GMBH & Cie. KG
Charterer	VOLANS Logistic
Type	Heavy Load Carrier
DWT	17287
Light Ship	6423.7



SHIPYARD		Ballast	6376 CBM (18 tanks)
Builder	Jiangxin Shipbuilding/ China 19-01-2012	Fresh Water	330.9 MT
Keel laid / builder No	12-31-2009 - JX622	Heavy Fuel Oil 100%	1300.8 MT
Classification Society	Lloyd Register	Heavy Fuel Consumption	MANV 20.0 MT/ 13.0 KN
Last Dry Dock	31-07-2023	Heavy Fuel Cons at berth	2.5 MT / 3.5 MT/24h
COMMUNICATION		MGO/LUB	314.7/103.2 MT
Inmarsat C TLX	420932112, Condorbilbao-C1@SkyFile-C.com	CRANES	
VSAT 1	+47 2367 7508 (Mapped German local number: +494087408694)	No. of Cranes	3 CRANES, NMF #1-150T, #2-150T, #3-80T
VSAT 2	+47 2367 7509	Max SWL/outreach 1&2	150T (4.5-16m), 120T (4.5-19m), 95T (4-24m), 70T (3.5-32m)
MOB	49 157 7887 2066	Max SWL/outreach 3	80T (4-18m), 65T (4-22m), 50T (3.5m-28m)
IRIDIUM	Phone +881677716151	EQUIPMENT	
E-mail:	master.condorbilbao@SkyFile.com	Bowthruster	700 KW
HF-Telex	209321000 newy x	Ballast pump	2 x 450 CBM
MMSI - ID	209321000	Fire Pump	2 x 230 CBM
MEASUREMENTS		Emergency Pump	1 x 65 CBM
LOA	144.85 m	Anchor chains P/S	9 & 10 shackles
LBP	134.87 m	Weight of Anchors	6000 kg
Bow to Brigde	123.20 m	Anchor Winch Pull	2 x 100 KN
Bridge to Stern	21.60 m	Mooring Winch Pull	2 x 100 KN
Breadth	22.80 m	PROPULSION	
Depth molded	13.35 m	Main Engine	HYUNDAY- 8580 KW
Summer draft	9.85 m	Auxiliary Engine	3 X 600 KW
Winter Draft	9.625 m	Emergency Generator	100 KW
Tropical Draft	10.035 m	Max Sea speed	16.0 Kn
FWA	204 mm	Tweendeck pontoons	444 MT
Keel to Mast	41.3 M	CARGO HOLDS	
CAPACITY		Hold #1 FR 144-175	2818.2 CBM
GRT	12795	Hold # 2 FR. 82-144	10436.7 CBM
NRT	5486	Hold # 3 FR. 39-78	6572.4 CBM
Containers	904 TEU	Hatch Covers	#1 (20.5 x 13.24M), #2 (38.5 X 18.6M) #3 (26.4 X 18.6M)

CARGO SPACE

300MT COMBINED LIFTING CAPACITY

CRANE 3: 80MT

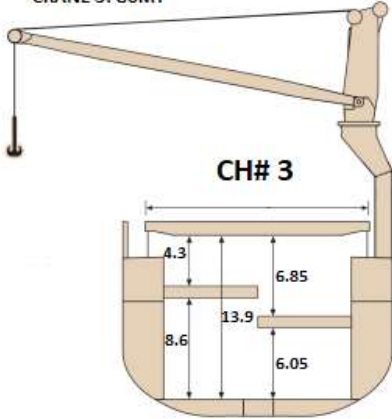

CRANE 2: 150MT

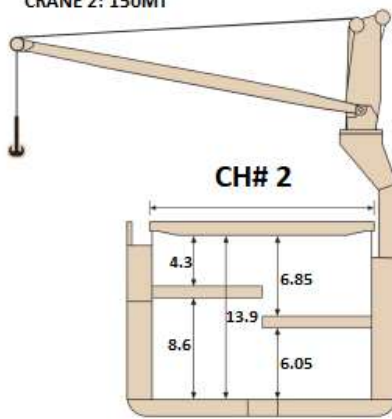

CRANE 1: 150MT

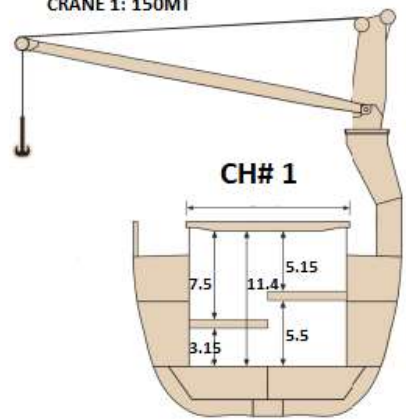

OUTREACH

**CRANE CAPACITY
80MT**

SWL	Min	Max
50mt	3.5 m	28.0 m
65mt	4.0 m	22.0 m
80mt	4.0 m	18.0 m

OUTREACH

**CRANE CAPACITY
150MT**

SWL	Min	Max
38mt	3.5 m	32.0 m
70mt	3.5 m	32.0 m
95mt	4.0 m	24.0 m
120mt	4.5 m	19.0 m
150mt	4.5 m	16.0 m

TWEEDECK

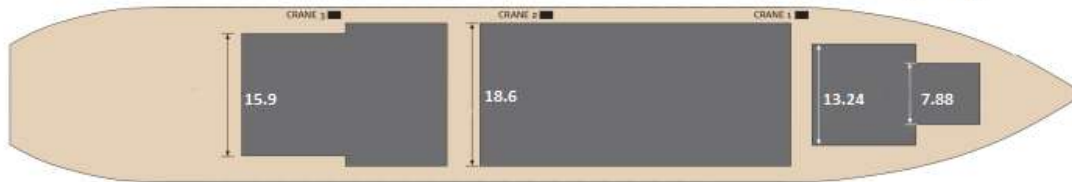

IN HOLD

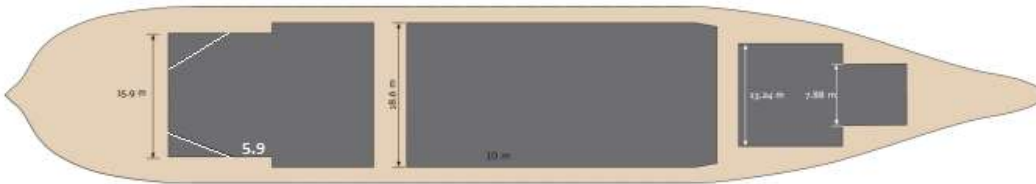

Obstruction in aft part of Hold 3 is 7.4 m long, 2.8 m wide and inclining upwards.

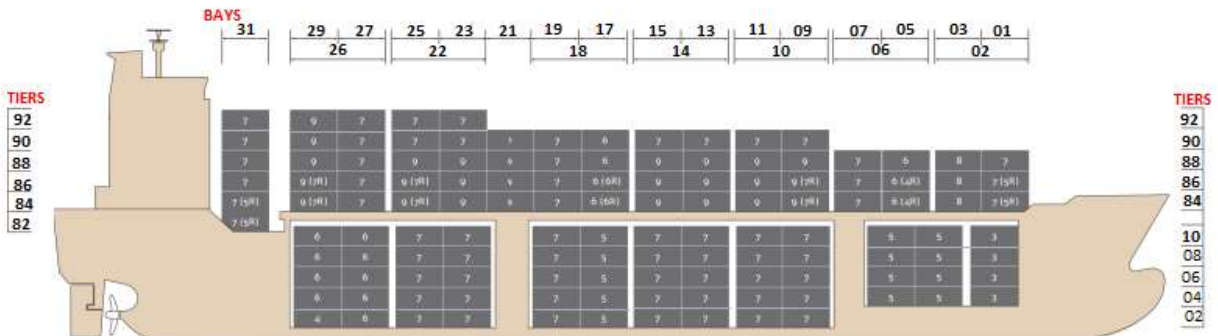

LOAD DISTRIBUTION	TANK TOP	TWEEDECK	HATCH COVER	MAIN DECK
Uniform load (mt/m ²)	18.0	Hold no. 1: 3.0 Hold no. 2 & 3: 3.5	2.2	2.2
Stack load TEU (mt) / no. in stack	150 / 5	40 / 2	60 / 5	60 / 6
Stack load FEU (mt) / no. in stack	175 / 5	60 / 2	90 / 5	90 / 6

IMO CREW LIST

IMO Convention on Facilitation of International Maritime Traffic

<input checked="" type="checkbox"/> Arrival <input type="checkbox"/> Departure												
1. Name of ship			2. Port of arrival / departure			3. Date of arrival / departure						
CONDOR BILBAO			Puerto Angamos, Chile			13 marzo 2026						
4A. Nationality of ship		5. Port arrived from		6. Nature and No of identity document (passport)		6A. Expiry date of (passport)		13. Sex		14. Place and Date of Embarkation		
CYPRUS		Chancay, Peru								dd-mm-yy		
4B. Official No.		7. Next Port :										
9473250		Valparaiso, Chile										
8.No	9. Family name; given names		10. Rank or rating	11. Nationality	12. Place and Date of birth							
1	Burdeyny	Oleksandr	Master	Ukrainian	Ukraine	30 jun 72	GK111189	07 ago 2034	M	Dunkerque 24 ene 26		
2	Hrushka	Artur	Chief Officer	Ukrainian	Ukraine	01 feb 97	GH709286	19 feb 2034	M	Antwerp 30 ene 26		
3	Chernyshov	Mykyta	Second Officer	Ukrainian	Ukraine	14 sept 93	FV322779	04 jun 2029	M	Antwerp 17 oct 25		
4	Abraamian	Anatolii	Third Officer	Ukrainian	Ukraine	29 dic 02	FT835995	18 ene 2029	M	Dunkerque 03 oct 25		
5	Prachyk	Vitalii	Chief Engineer	Ukrainian	Ukraine	21 abr 91	FG909273	11 jul 2027	M	Antwerp 30 ene 26		
6	Baglayev	Igor	Second Engineer	Ukrainian	Ukraine	03 jul 69	FE631208	21 jun 2026	M	Bilbao 22 oct 25		
7	Chechelnytsky	Stanislav	Third Engineer	Ukrainian	Ukraine	06 may 69	GL020493	31 ene 2035	M	Bilbao 22 oct 25		
8	Bezuhlyi	Oleksandr	Electrician	Ukrainian	Ukraine	29 jul 95	FJ423635	24 oct 2027	M	Dunkerque 21 ene 26		
9	Myronovych	Volodymyr	Bosun	Ukrainian	Ukraine	03 sept 76	GM377992	25 ago 2035	M	Bilbao 16 ene 26		
10	Balaba	Raymund	AB	Filipino	Duero Bohol	15 sept 83	P6146945B	21 ene 2031	M	Bilbao 22 oct 25		
11	Roncal	Reggie	AB	Filipino	Manila	22 sept 82	P2834775B	21 ago 2029	M	Antwerp 03 jul 25		
12	Arellano	Joshua	OS	Filipino	Camalaniugan Cagayan	03 feb 00	P6975703B	13 jun 2031	M	Bilbao 22 oct 25		
13	Ravina	Harvey	OS	Filipino	Cebu	20 sept 93	P5392607B	09 ago 2030	M	Antwerp 30 ene 26		
14	Frentiu	Dorel	Deck Fitter	Romanian	Constanta, Romania	07 oct 61	059319052	14 oct 2030	M	Dunkerque 03 oct 25		
15	Tril	Dmytro	Engine Fitter	Ukraine	Ukraine	04 jul 82	FH091990	25 jul 2027	M	Antwerp 30 ene 26		
16	Ardena	Rogelio Jr.	Oiler	Filipino	Sagay Neg Oc	17 sept 72	P2979691B	05 sept 2029	M	Dunkerque 21 ene 26		
17	Mata	Marvin Jay	Wiper	Filipino	Iloilo	19 nov 99	P0200862C	22 may 2032	M	Antwerp 30 ene 26		
18	Dadis	Chester Paul	Deck Cadet	Filipino	Angono Rizal	02 ene 00	P1875176C	03 oct 2032	M	Antwerp 03 jul 25		
19	Antazo	Danilo	Chief Cook	Filipino	Nasugbu Batangas	18 dic 69	P2225090B	20 may 2029	M	Dunkerque 21-ene-26		
20	Gonzales	Michael	Messman	Filipino	San Juan Batangas	03 jun 94	P5082452B	09 mar 2030	M	Antwerp 30 ene 26		

12. Date and signature by master, authorized agent or officer

capt. Burdeyny Oleksandr

13-03-2026